

Datasheet

Aircore EC Frame 18, 7.5 HP, 1800 RPM

Motor and drive all in one

Integrated variable frequency drive (VFD) facilitates variable speed applications, reducing overall energy usage.

Power more with less

50% lighter, 30% quieter and 10% more efficient than traditional AC induction motors.



Powerful intelligence

- State-of-the-art VFD allows precise speed control, reduces energy usage, and operates at a frequency to minimize audible noise.
- I-con (motor control software) enables users to fine tune operational parameters to their specific applications.
- Maximum power density in a 50% smaller and lighter package.

Optimized efficiency

- Meets highest efficiency standards at a wide range of load conditions.
- Increased operational efficiency by eliminating torque ripple, cogging, stator hysteresis and eddy current losses.
- Compact form factor reduces wiring and facilitates direct mounting to fan applications, increasing efficiency by 10-15%.

Sustainable solution

- PCB stator uses 66% less copper and has proven to be 10x more reliable than traditional iron-core, copper-wound stators.
- Smaller and lighter housing reduces transportation emissions by 30%.
- Easy serviceability through our modular design enables the reuse and extended lifespan of components, keeping them out of the landfill.

Applications



Commercial HVAC



Pumps



Material handling

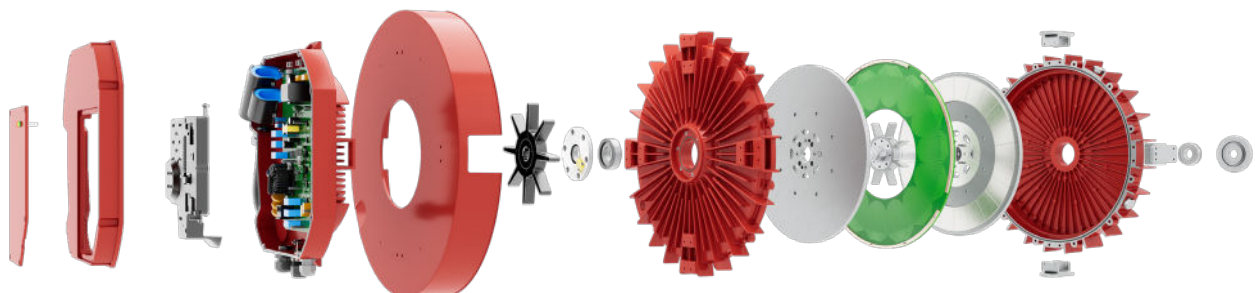

Performance

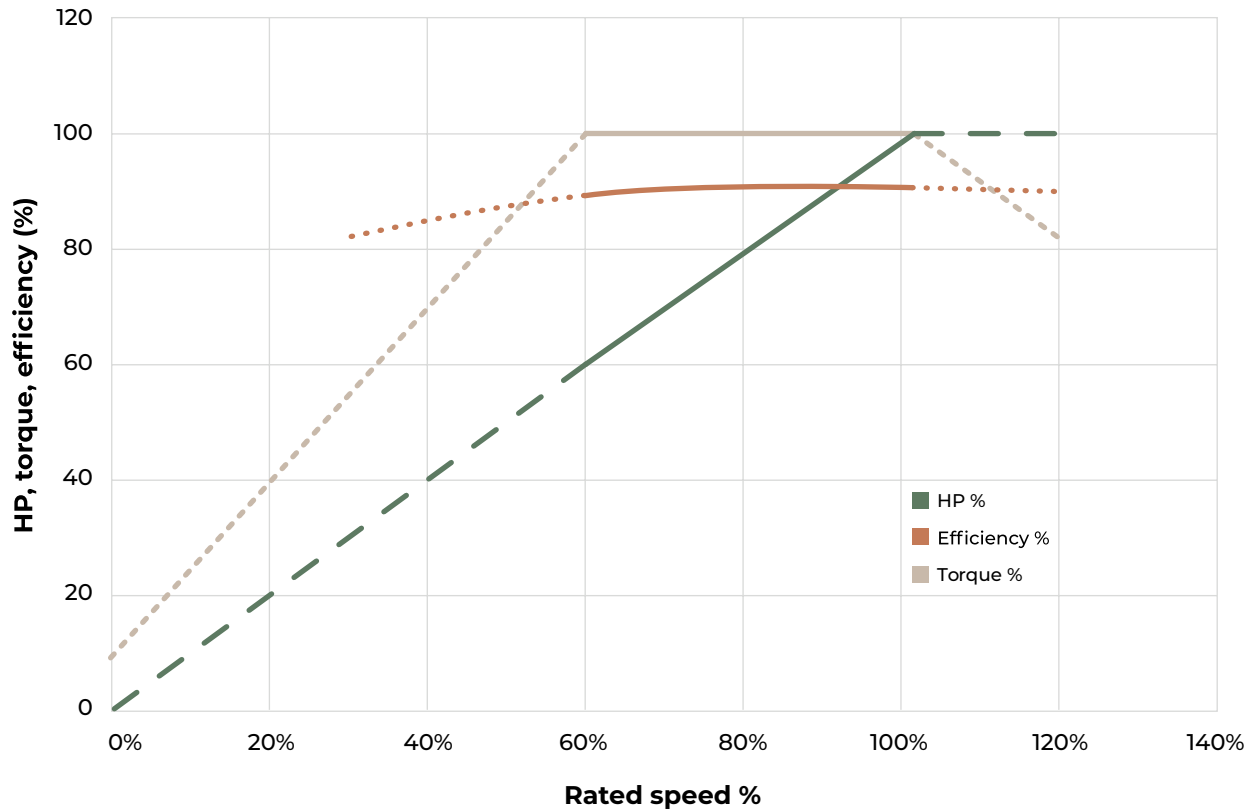

Note: Infinitum does not recommend using the motor below 60% of rated speed except when coasting or ramping up. It is also essential to restrict power and FLA within the nameplate rating when operating the motor above 100% of its rated speed. To operate the motor outside the recommended operating range, please contact the factory and our Application Engineers will provide a customized solution.

Motor information	
Rated power	7.5HP, 5.6 kW
Rated torque	22.1 lb-ft, 30.0 Nm
Rated speed	1800 RPM
Max speed	2160 RPM (see above)
Min speed	100 RPM (see above)
Weight (motor & drive)	96.1 lbs, 43.6 kg
Frame diameter	18.6", 47.2 cm
Length (motor & drive)	8.7", 22.1 cm
System efficiency	91%
Duty cycle	Continuous
Variable speed	Yes, integrated VFD
Service factor	1.0
Motor thermal protection	Electronically-protected L
Motor type	TEFC
Enclosure rating	IP54

Electrical	
Supply voltage	460 VAC ± 10%
Supply phase	3 Phase
Supply voltage frequency	60 Hz ± 5%
Voltage imbalance	± 3% Phase to phase voltage
Short circuit current rating (SCCR)	Input – 5 kA, 500 V maximum
Rated amps	9.0 A (460 VAC)
Motor insulation class	B

Mechanical	
Direction of rotation	CW/CCW
Motor frame material	Aluminum
Rotor inertia	0.49 kg/m ²
Bearing type – DE	Standard: steel, 6206 sealed, permanently lubricated Optional: hybrid ceramic (see catalog number)
Bearing type – NDE	Standard: steel, 6206 sealed, permanently lubricated Optional: hybrid ceramic (see catalog number)
Grease specification	Mobil polyrex EM
Regreasable	No
Grounding brushes	Included – DE
Shaft design	Keyed
Motor mounting position	Horizontal or vertical
Motor mounting type	C-face (182TC) and body mount

Ambient operating conditions		
Condition	Operation	Storage & transportation
Altitude	0 to 3300 ft. (1,000 m) above sea level 9% power derate per 1,000 m up to 4,000 m	NA
Ambient temperature	-13 to 104 °F (-25 to 40 °C) 2% power derate per 1 °C up to 50 °C	-40 to 185 °F (-40 to 85 °C)
Relative humidity	95%, No condensation allowed	95%, No condensation allowed
Contamination levels	No conductive dust allowed	No conductive dust allowed

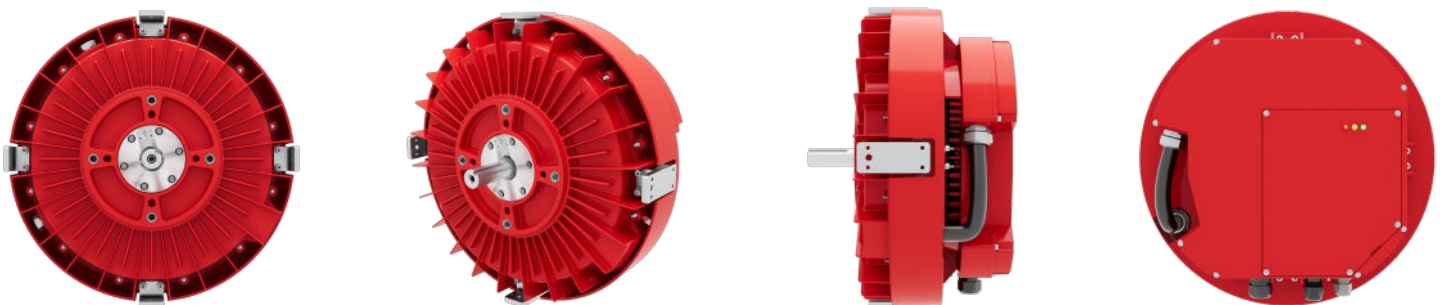

Control connections

Refer to [IOM Manual](#) for more details.

Note: not all I/Os are supported in every motor. (See catalog number)

Description	Quantity	Type
Analog input Software selectable for voltage or current input	1	Voltage signal – 0 to 10 VDC, RIN = 20 k Ω Current signal – 0 to 20 mA, RIN = 500 Ω Resolution – 0.1% Accuracy – \pm 5%
Analog output (see above) Software selectable for voltage or current output	1	Voltage – 0 to 10 VDC with 10 mA maximum Current – 0 to 20 mA with load < 500 Ω
Auxiliary voltage	1	24 VDC user supply with \pm 5% with 1 A maximum
Digital input	4	24 VDC with internal or external supply Input impedance – 1 k Ω
Digital output	2	Open drain output Maximum switching voltage 40 VDC Maximum switching current 350 mA
Relay output	1	Normally open (NO), normally closed (NC) contact arrangements Maximum switching voltage of 125 VAC / 30 VDC Maximum switching current of: NO – 10 A (VAC) / 5 A (VDC) NC – 3 A (VAC) / 3 A (VDC)
EIA-485 Interface for Modbus RTU	1	Shielded twisted pair cable with impedance of 120 Ω Transfer rate of 19200 baud Half duplex Modbus communication protocol
Modbus TCP	1	Ethernet

Certifications

Regulatory	
UL 1004-7	Standard for electronically protected motors
UL 1004-1	Rotating electrical machines – general requirements
CSA C22.2 No.77	Motors with inherent overheating protection
UL 61800-5-1	Standard for adjustable speed electrical power drive systems, Part 5-1: safety requirements & electrical, thermal & energy



Mounting & dimensions

Below are the measurements needed for installation tasks.

- There are four mounting pad locations.
- Each pad is spaced 90° apart, containing 4 mounting holes and one lifting eye hole.
- The DE face of the mounting block has threaded holes for four bolts (1/2"-13).
- All bolt holes should be used for secure mounting of the motor to equipment.

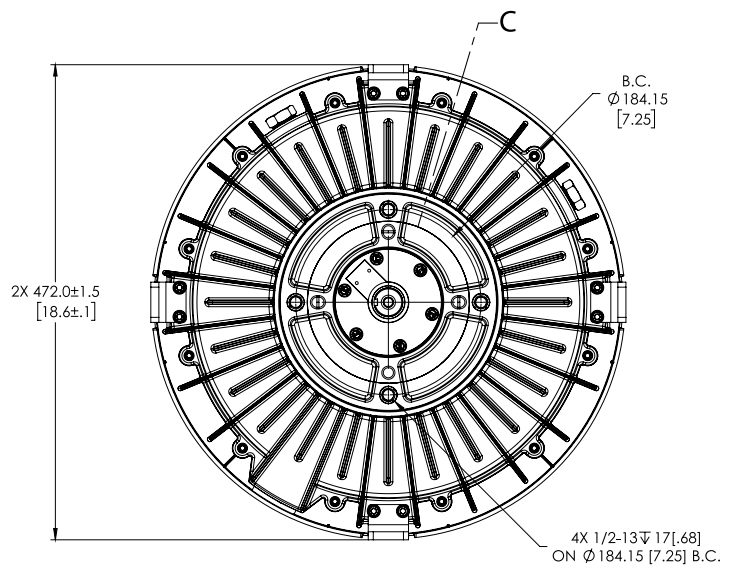
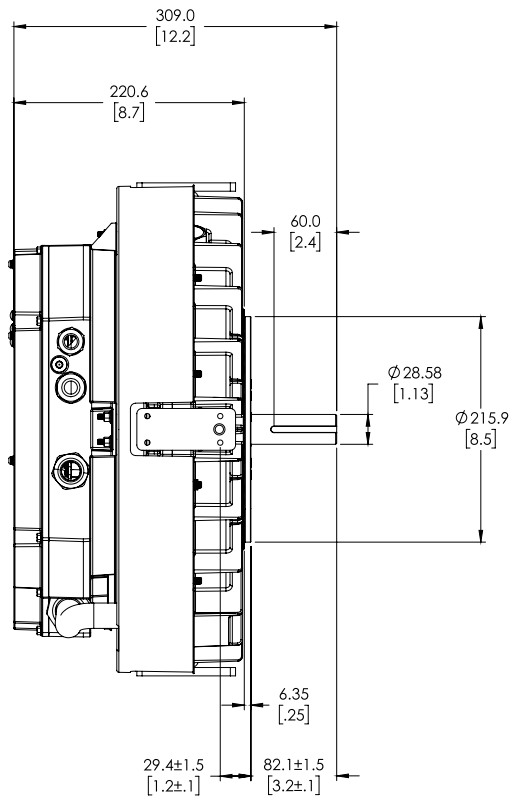
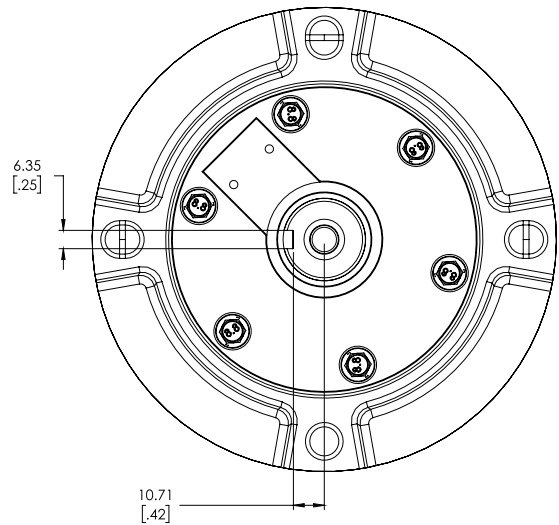
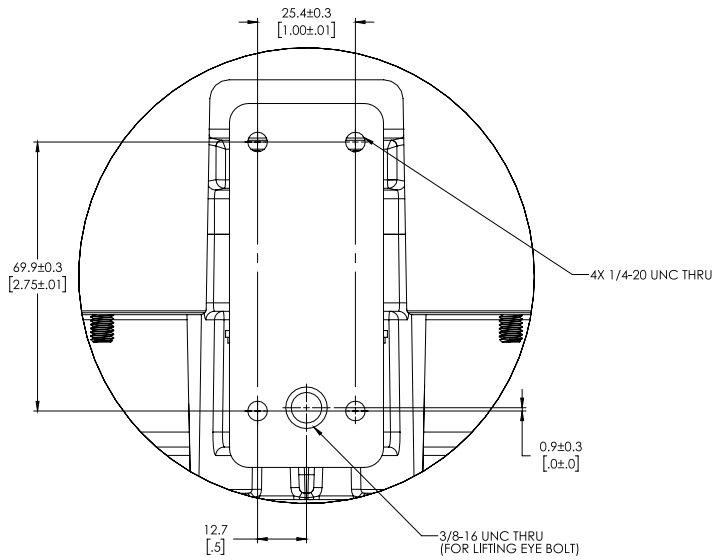
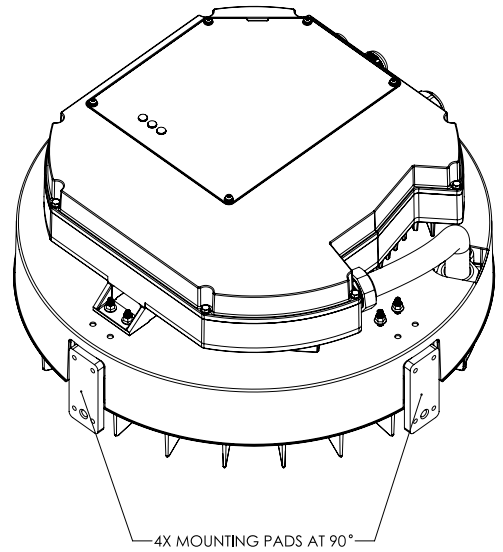

Catalog number decoder

Family	Frame	Rated power	Rated speed	Volts	VFD & I/O	Comm module	Bearings	Shaft length	Xbee module	IP rating	Misc
XX	XX	XXXX	XXXX	X	X	X	X	X	X	X	X
AE	18	0750	1800	A*: 460 V / 60 Hz	A*: Modbus, analog input	A*: none	S*: steel H: hybrid	A*: 3.3" B: 4.0	A*: none	4*: IP54	0*: EPL

*Standard

Example catalog number

AE18-0750-1800-AAAS-AA40

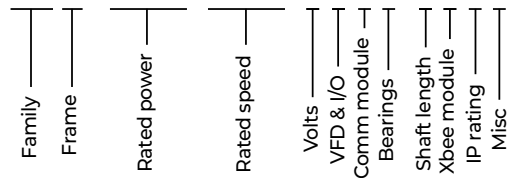

Example decoded

AE18 = Aircore EC, 18 frame

0750 = 7.5 HP

1800 = 1800 RPM

AAAS = 460 V / Modbus / Analog Input / No communication module / Steel bearings

AA40 = 3.3" shaft length / No IoT module / IP54 rating / Electronically Protected-L

Ordering information

Catalog number	Description
AE18-0750-1800-AAAS-AA40	Aircore EC, frame 18, 7.5 HP, 1800 RPM, 460 V / 60 Hz, Modbus RTU, analog input, no comm module, steel bearing, standard shaft, no Xbee module, IP54, electronically protected for locked rotor
AE18-0750-1800-AAAH-AA40	Aircore EC, frame 18, 7.5 HP, 1800 RPM, 460 V / 60 Hz, Modbus RTU, analog input, no comm module, hybrid bearing, standard shaft, no Xbee module, IP54, electronically protected for locked rotor
AE18-0750-1800-AAAS-BA40	Aircore EC, frame 18, 7.5 HP, 1800 RPM, 460 V / 60 Hz, Modbus RTU, analog input, no comm module, steel bearing, custom shaft, no Xbee module, IP54, electronically protected for locked rotor
AE18-0750-1800-AAAH-BA40	Aircore EC, frame 18, 7.5 HP, 1800 RPM, 460 V / 60 Hz, Modbus RTU, analog input, no comm module, hybrid bearing, custom shaft, no Xbee module, IP54, electronically protected for locked rotor



We reserve the right to make technical changes or modify the contents of this document without prior notice. Copyright© 2023 Infinitum Electric, Inc. All rights reserved.

Office

106 Old Settlers Blvd
Suite D106
Round Rock, TX 78664

Contact

info@goinfinitum.com
goinfinitum.com
support.goinfinitum.com